



Fluid Control

Our product brands:

IMI Buschjost

IMI FAS

IMI Herion

Customised Control Solutions

Breakthrough
engineering for
a better world



Contents	Introduction	2
	Customised solutions	3
	Global reach	4
	Enclosed and open panels	6
	Modular units, customised actuators	7

Breakthrough engineering for a better world

We create breakthrough solutions which accelerate the safety, reliability and performance of everyday processes. Our valves and complete system solutions control liquids and gases, enabling machine builders to improve design functionality and keep safety and sustainability at the forefront of innovation.

For over 80 years, we have helped our customers improve the reliability and efficiency of their machines for diverse end markets. Working in close customer partnership, we continuously push the boundaries of technology, offering a wide selection of components and tailored solutions. Meeting equipment manufacturers' needs includes everything from helping provide traceability for consumers, to reducing waste in critical resources and delivering a premium cup of coffee.

Through flexible, scalable and agile innovation, we help our customers solve their current challenges and create competitive advantage for the future.

Breakthrough engineering you can count on.

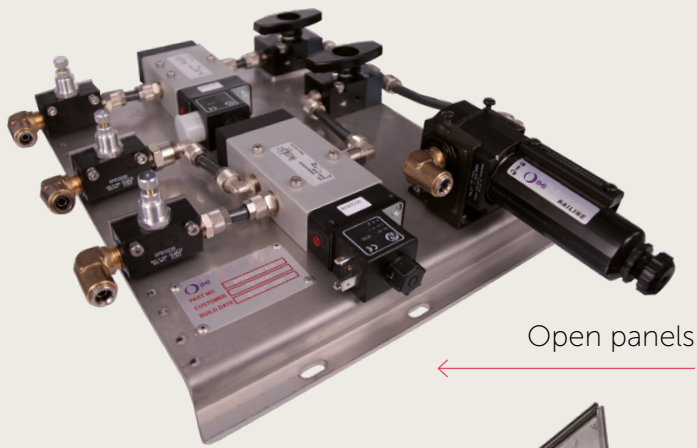

Open panels

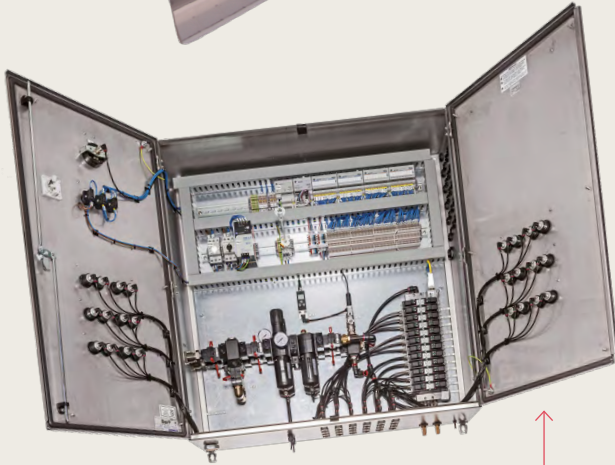

Enclosed panels

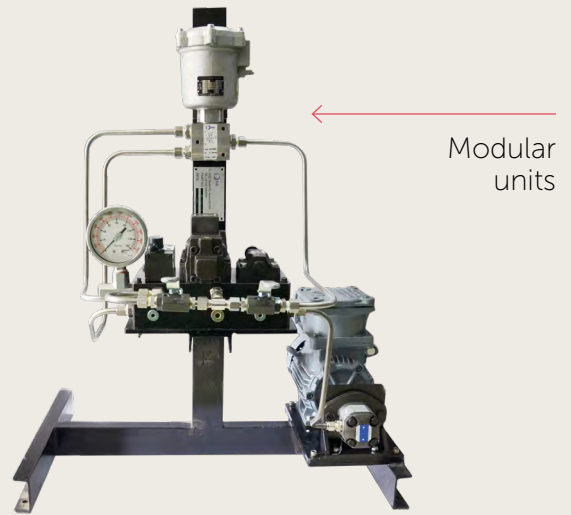

Modular units



Customised actuators

Customised solutions

From design concept to commissioning support, benefit from our expertise. Thanks to our many years of experience in various industrial sectors, we are able to meet almost any requirement, from simple pneumatic and electropneumatic controls to complex systems.

Integrated expert service

Fulfilling the needs of our customers is at the heart of everything we do. Using your specifications as the foundation and providing you with excellent technical support, so you can make informed decisions, we can design the optimal solution for your application.

Whether you need an enclosed panel, open panel, modular unit or customised actuator, we have the competence on hand to serve you. In addition to products from our standard range, we can also draw on a wide range of special designs and new developments.

- Facilitated procurement process by using only one order number
- High-quality products
- Increased process safety
- Reduced inventory holding costs
- Rapid response times
- On-site installation support
- Plug-and-play installation on site
- Improved energy efficiency
- Documentation
- Service contract support

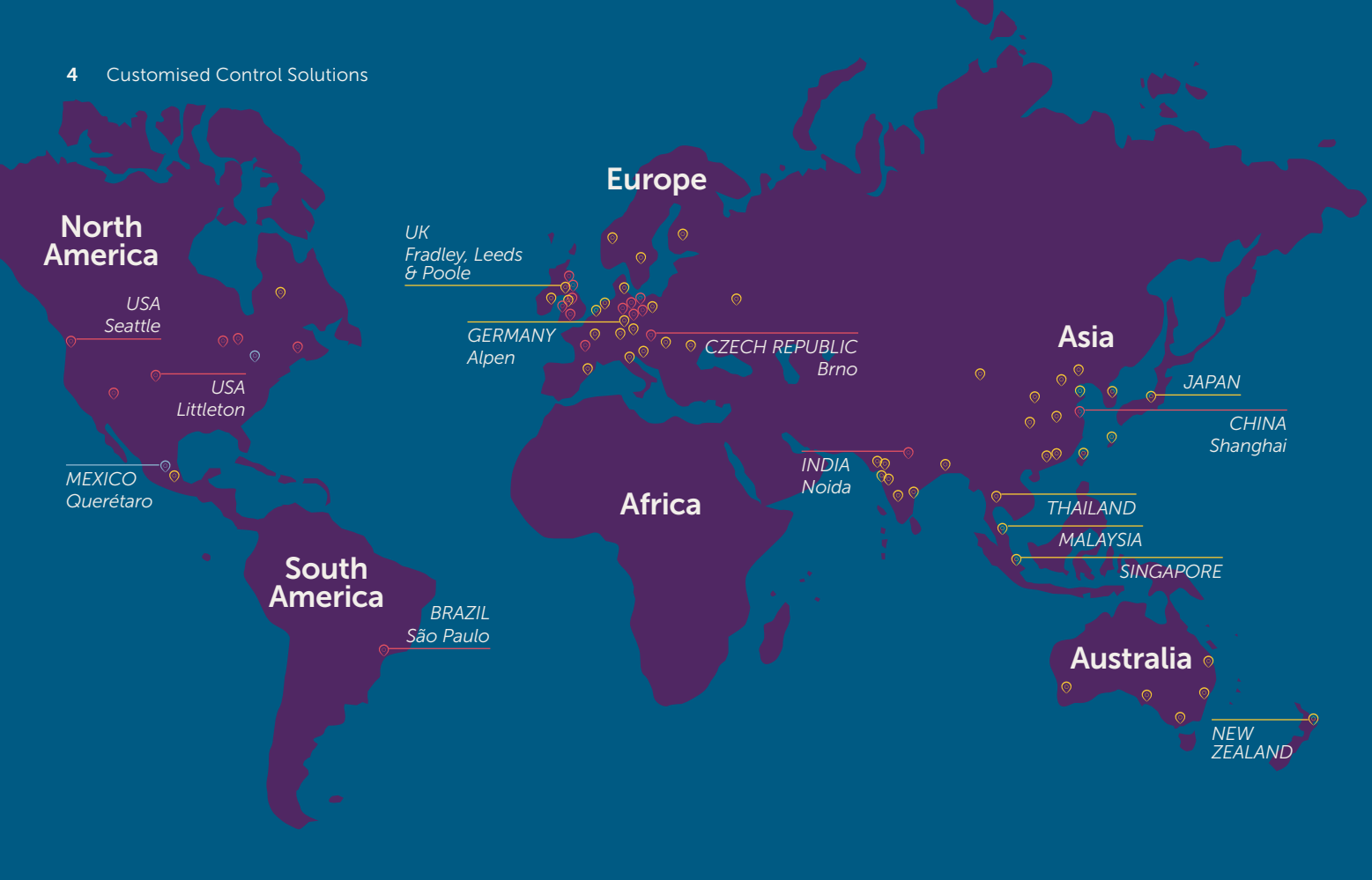

Global reach



Enquiry

A reliable engineering source

Making full use of the global IMI network, we are able to assign the best engineering teams to assist with your enquiry. We use our extensive industry expertise to offer our customers individual solutions and a technical competitive advantage.

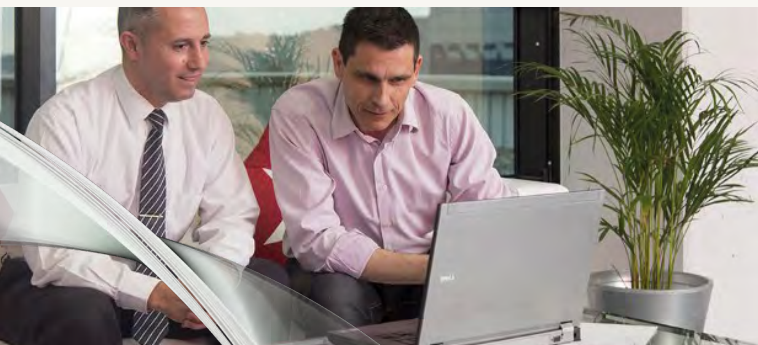

Consultation

Where your needs will be heard

We take the time to listen and understand our customers' needs, and make sure we have the presence on the ground, wherever it's needed. To deliver this, we've established strong local teams across Europe, the Americas and Asia. Whether it is a one-off order or batch production, we have the resources in place to support you.



Concept

Designed to your specification

Our dedicated technical experts will engage with you to create a design to suit your individual specifications and requirements.

Safety technology

With over 50 years of experience in safety applications, we make it easy for you to protect man and machine.

Important safety features such as:

- Safety applications DIN EN ISO 13849
- Competent and professional consulting and system design of safety controls
- DGUV-certified, self-monitoring safety valves
- Very high B10 values
- Safe exhaust
- Safe position
- Safe stop
- Reliable reversing
- Safely limited speed and more

Sales & Service in 50 countries

- Sales, manufacturing and technical centres
- Sales locations
- Manufacturing locations

Production

Using high quality products

We take responsibility for the full supply chain - therefore taking the burden off you - and will only use quality high performing products to build your desired solution. Our workshops are staffed with highly skilled panel builders who secure precision build for you and ensure timely turnarounds for your projects.



Logistic

Ready for plug-and-play

We commit to providing timely delivery, fully tested at your door step with your solution as requested, ready to operate instantly with just a few quick and easy steps. All you need to do is 'Plug and Play'.



Customised solutions for your needs

Our high performance products have application in all sectors, and we have particular expertise of Factory Automation, Food & Beverage, Rail, Commercial Vehicles, Life Sciences and Energy.

With over 30 years' experience in each, we use our deep understanding of the technical challenges and legislative framework to develop pioneering platform products to answer specific needs. In this way, we help more customers enjoy solutions that deliver cost and energy savings, a simplified supply chain and a reduction in machine complexity.

●● Call your local IMI sales team or visit our website for more information on our customised control solutions! ●●

Enclosed panels

Customised & Engineered to your needs

- Reliable
- Comes with complete documentation
- Plug and Play design
- Ease of maintenance



Open panels

Option to mount locally on critical equipment

- Shock & vibration testing to EN61373 for rail applications.
- Suitable for extreme temperatures.
- Redundant valve systems.
- Maximum safety (SIL measurement).
- High pressure (Up to 40 bar)



Modular units

Compact, robust & modular solutions

- Reliable integrated control solution for various pressure setting
- Easy to install and maintain
- Compact, robust and modular solutions

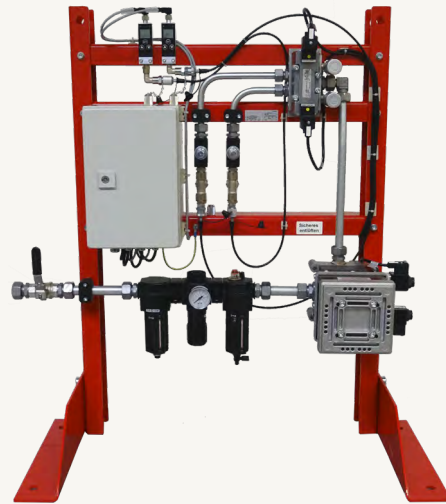

Customised actuators

Specially developed and tested

- High reliability and performance
- Suitable for harsh environments
- 3 position actuator
- Actuator with positioner
- Large bore and stroke sizes available
- Multi-piston actuator
- Full functional testing

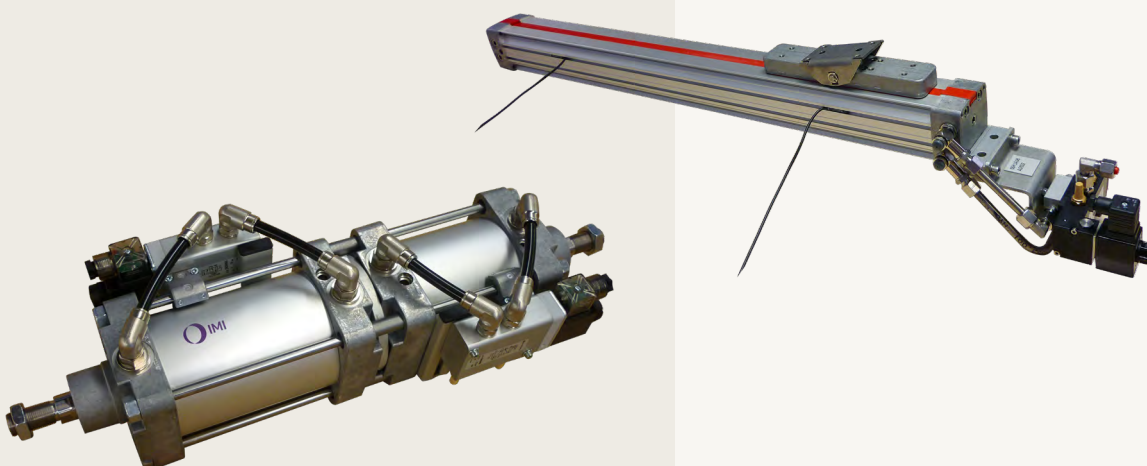
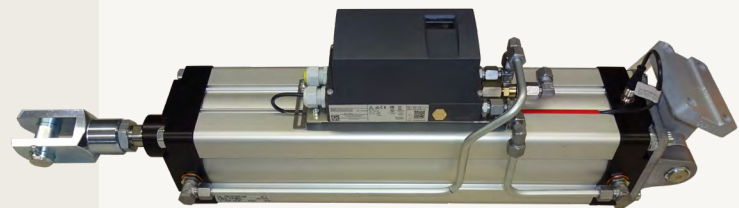

IMI operates four global centres of technical excellence and a sales and service network in 50 countries, as well as manufacturing capability in Brazil, China, the Czech Republic, Germany, India, Mexico, Switzerland, the UK and the USA.

Supported by distributors worldwide.

For further information, scan this QR code or visit

www.imiplc.com



Fluid Control

Our product brands:

IMI Buschjost

IMI FAS

IMI Herion

Due to our policy of continuous development, IMI reserves the right to change specifications without prior notice.

z10247BR en/06/24

