

82590/84490

2/2-way diaphragm valves

- Port size: DN 8 ... 50, 1/4 ... 2 (ISO G/NPT)
- High flow rate
- For robust industry solutions
- Damped operation
- Suitable for vacuum
- For systems with low or fluctuating pressure
- Valve operates without differential pressure
- Solenoid interchangeable without tools (Click-on®)
- International approvals



Technical features

Medium:
Slightly aggressive gases and liquids

Switching function:
Normally closed

Operation:
Solenoid actuated, with forced lifting

Mounting position:
Optional, preferably solenoid vertical on top

Flow direction:
Determined

Port size:
G1/4, G3/8, G1/2, G3/4, G1, G1 1/4, G1 1/2, G2 1/4 NPT, 3/8 NPT, 1/2 NPT, 3/4 NPT, 1 NPT, 1 1/4 NPT, 1 1/2 NPT, 2 NPT

Operating pressure:
See table

Fluid temperature:
-10° ... +90°C (+14° ... +194°F)

Ambient temperature:
-10° ... +50°C (+14° ... +122°F)

Material:
Body: Stainless steel (1.4408)
Seat seal: NBR
Internal parts: Stainless steel, PVDF

For contaminated fluids insertion of a strainer is recommended.

Technical data – standard models

Symbol	Port size	Orifice (mm)	Flow kv value *1) (m³/h)	Operating pressure *2)		Weight (kg)	Model	
				(bar)	(psi)		Solenoid V d.c.	Solenoid V a.c.
	G1/4	8	1,9	0 ... 10	0 ... 145	0,7	8259000.9151.xxxxx	8259000.9154.xxxxx
	1/4 NPT	8	1,9	0 ... 10	0 ... 145	0,7	8449000.9151.xxxxx	8449000.9154.xxxxx
	G3/8	10	3	0 ... 10	0 ... 145	0,7	8259100.9151.xxxxx	8259100.9154.xxxxx
	3/8 NPT	10	3	0 ... 10	0 ... 145	0,7	8449100.9151.xxxxx	8449100.9154.xxxxx
	G1/2	12	3,4	0 ... 10	0 ... 145	0,8	8259200.9151.xxxxx	8259200.9154.xxxxx
	1/2 NPT	12	3,4	0 ... 10	0 ... 145	0,8	8449200.9151.xxxxx	8449200.9154.xxxxx
	G3/4	20	5,8	0 ... 10	0 ... 145	0,9	8259300.9151.xxxxx	8259300.9154.xxxxx
	3/4 NPT	20	5,8	0 ... 10	0 ... 145	0,9	8449300.9151.xxxxx	8449300.9154.xxxxx
	G1	25	8	0 ... 10	0 ... 145	1,3	8259400.9151.xxxxx	8259400.9154.xxxxx
	1 NPT	25	8	0 ... 10	0 ... 145	1,3	8449400.9151.xxxxx	8449400.9154.xxxxx
	G1 1/4	32	23	0 ... 16	0 ... 232	4,3	8259500.9401.xxxxx	8259500.9404.xxxxx
	1 1/4 NPT	32	23	0 ... 16	0 ... 232	4,3	8449500.9401.xxxxx	8449500.9404.xxxxx
	G1 1/2	40	25	0 ... 16	0 ... 232	4,1	8259600.9401.xxxxx	8259600.9404.xxxxx
	1 1/2 NPT	40	25	0 ... 16	0 ... 232	4,1	8449600.9401.xxxxx	8449600.9404.xxxxx
	G2	50	41	0 ... 16	0 ... 232	5,1	8259700.9401.xxxxx	8259700.9404.xxxxx
	2 NPT	50	41	0 ... 16	0 ... 232	5,1	8449700.9401.xxxxx	8449700.9404.xxxxx

xxxxx Please insert voltage and frequency codes

*1) Cv-value (US) ≈ kv value x 1,2

*2) For gases and liquid fluids up to 25 mm²/s (cSt)

G1/4 ... G1 resp. 1/4 NPT ... 1 NPT max. 16 bar on request

Option selector

8**9***.***.***

Thread form	Substitute
ISO G	25
NPT	44
Port size	Substitute
1/4	0
3/8	1
1/2	2
3/4	3
1	4
1 1/4	5
1 1/2	6
2	7
Valve options	Substitute
Normally open (NO), up to G1 (1 NPT) with solenoid 9150 max. 10 bar (145 psi), with solenoid 8300 max. 16 bar (232 psi), with solenoid 9300 max. 16 bar (232 psi), from G1 1/4 (1 1/4 NPT) only with solenoid 8400 max. 16 bar (232 psi)	01
Manual override	02
Seat seal FPM, Fluid temperature -5 ... +110°C	03
Seat seal EPDM, for hot water, Fluid temperature -10 ... +110°C	14
Normally open, Seat seal FPM, Fluid temperature -5 ... +110°C, from G1 1/4 (1 1/4 NPT) only with solenoid 8400	17
Version for drinking water with test according to KTW up to max. G1	88
Version for drinking water with test according to KTW Normally open (NO), up to G1 0,3 ... 16 bar (4,35 ... 232 psi)	89

Frequency	Substitute
See table frequency codes	xx
Voltage	Substitute
See table voltage codes	xxx
Solenoid options	Substitute
G1/4 ... 1 Operating pressure 0 ... 10 bar Solenoid in V d.c.	9151
G1 1/4 ... 2 Operating pressure 0 ... 16 bar Solenoid in V d.c.	9401
G1/4 ... 1 Operating pressure 0 ... 10 bar Solenoid in V a.c.	9154
G1 1/4 ... 2 Operating pressure 0 ... 16 bar Solenoid in V a.c.	9404

Standard solenoid systems

Voltage and Frequency Solenoid 9151/9154 *3)					
Code Voltage	Code Frequency	Voltage	Frequency	Power consumption	
				Inrush	Holding
024	00	24 V d.c.	-	18 W	18 W
024	49	24 V a.c. *4)	40 ... 60 Hz	20 VA	20 VA
110	49	110 V a.c. *4)	40 ... 60 Hz	20 VA	20 VA
120	49	120 V a.c. *4)	40 ... 60 Hz	20 VA	20 VA
230	49	230 V a.c. *4)	40 ... 60 Hz	20 VA	20 VA
Voltage and Frequency Solenoid 9301/9304 *3)					
024	00	24 V d.c.	-	18 W	18 W
024	49	24 V a.c. *4)	50 Hz	20 VA	20 Hz
110	49	110 V a.c. *4)	50 Hz	20 VA	20 Hz
120	49	120 V a.c. *4)	60 Hz	20 VA	20 Hz
230	49	230 V a.c. *4)	50 Hz	20 VA	20 Hz
Voltage and Frequency Solenoid 9401/9404 *3)					
024	00	24 V d.c.	-	38 W	38 W
024	49	24 V a.c. *4)	40 ... 60 Hz	42 VA	42 VA
110	49	110 V a.c. *4)	40 ... 60 Hz	42 VA	42 VA
120	49	120 V a.c. *4)	40 ... 60 Hz	42 VA	42 VA
230	49	230 V a.c. *4)	40 ... 60 Hz	42 VA	42 VA
Voltage and Frequency Solenoid 8401/8404					
024	00	24 V d.c.	-	40 W	40 W
024	49	24 V a.c. *4)	40 ... 60 Hz	45 VA	45 VA
110	49	110 V a.c. *4)	40 ... 60 Hz	45 VA	45 VA
120	49	120 V a.c. *4)	40 ... 60 Hz	45 VA	45 VA
230	49	230 V a.c. *4)	40 ... 60 Hz	45 VA	45 VA

*3)  only (with the exception of solenoid 94xx up to 41 V a.c.)

*4) A.c. only with rectifier plug

*5) D.c. only, for a.c. solenoids with design inspection certificate acc. to category 2, e.g. 6120 or 6240

Further versions on request!

Electrical details for all solenoid systems

Design	DIN VDE 0580
Voltage range	±10%
Duty cycle	100% ED
Protection class	EN 60529 IP65
Socket	Form A acc. to DIN EN 175301-803 (included)

According to DIN VDE 0580 at a solenoid temperature of +20°C.

At operating state temperature the input power of a coil decreases by up to ca. 30% due to physical reasons.

Additional solenoid systems for hazardous areas

ATEX-category	ATEX-protection class	IP-protection class	Solenoid	Standard voltages
II3G II3D	Ex ec IIC T4 Gc Ex tc IIIC T130°C DC	IP65	8426 *5)	24 V d.c.
II3G II3D	Ex ec IIC T4 Gc Ex tc IIIC T130°C DC	IP65	9176 *5)	24 V d.c.
II3G II3D	Ex ec IIC T4 Gc Ex tc IIIC T130°C DC	IP65	9426 *5)	24 V d.c.
II 2G II 2D	Ex eb mb IIC T3 Gb Ex mb tb IIIB T140°C Db	IP66	6120	24 V d.c., 110 V a.c., 230 V a.c.
II 2G II 2D	Ex eb mb IIC T3 Gb Ex mb tb IIIB T140°C Db	IP66	6240	24 V d.c., 110 V a.c., 230 V a.c.

Attention!

The conditions imposed on the Ex approvals lead to reduction of the permissible standard temperature ranges in the cases of explosion protected solenoids.

Dimensions

G1/4 ... 1
1/4 ... 1 NPT

Dimensions in mm
Projection/first angle

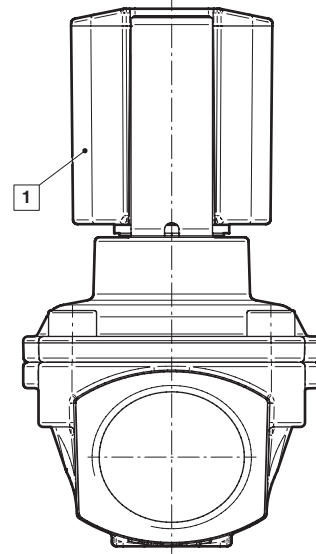
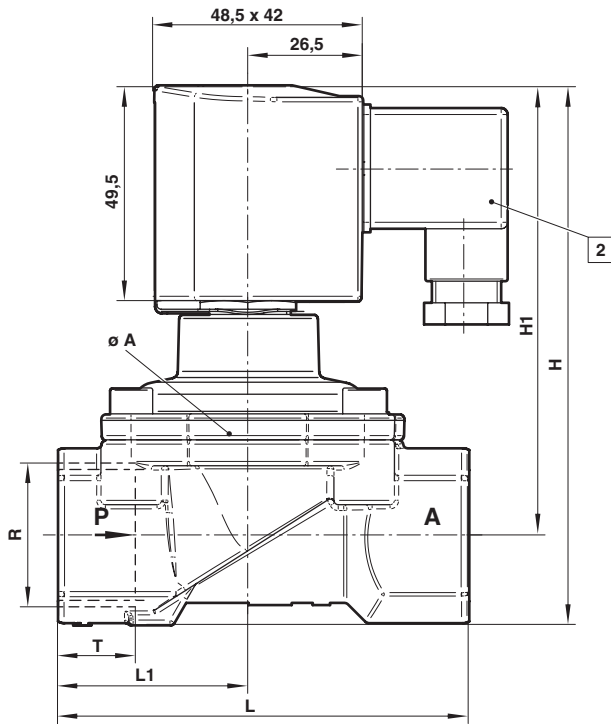

G1 1/4 ... 2
1 1/4 ... 2 NPT

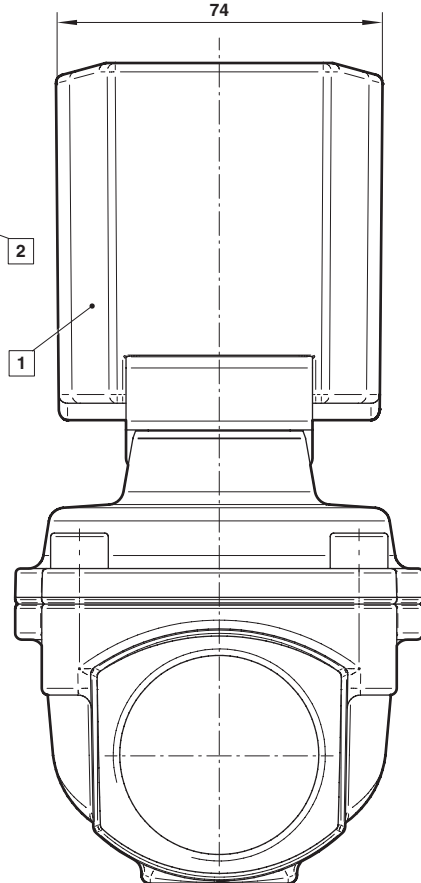
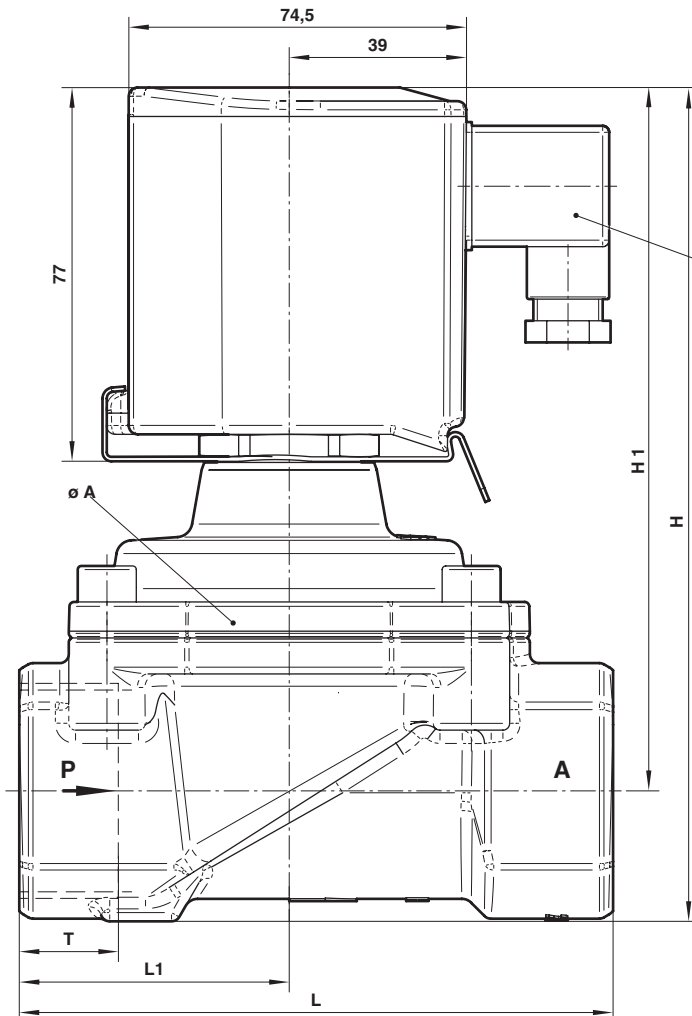

- 1 Solenoid rotatable 360°
- 2 Socket turnable 4 x 90°
(Socket included)

Dimensions

G1/4 ... 2

1/4 ... 2 NPT

Port size R	ø A	H	H1	L	L1	T	Model
G1/4	44	104	92,5	60	27,5	12	8259000.915x.xxxxx
1/4 NPT	44	104	92,5	60	27,5	10	8449000.915x.xxxxx
G3/8	44	104	92,5	60	27,5	12	8259100.915x.xxxxx
3/8 NPT	44	104	92,5	60	27,5	10,5	8449100.915x.xxxxx
G1/2	44	108	94,5	67	31	14	8259200.915x.xxxxx
1/2 NPT	44	108	94,5	67	31	13,5	8449200.915x.xxxxx
G3/4	50	115	99	80	36,5	16	8259300.915x.xxxxx
3/4 NPT	50	115	99	80	36,5	14	8449300.915x.xxxxx
G1	62	124	103,5	95	44	18	8259400.915x.xxxxx
1 NPT	62	124	103,5	95	44	17	8449400.915x.xxxxx
G1 1/4	92	186	157	132	60	20	8259500.940x.xxxxx
1 1/4 NPT	92	186	157	132	60	17	8449500.940x.xxxxx
G1 1/2	92	186	157	132	60	22	8259600.940x.xxxxx
1 1/2 NPT	92	186	157	132	60	17	8449600.940x.xxxxx
G2	109	201,5	167	160	74	24	8259700.940x.xxxxx
2 NPT	109	201,5	167	160	74	17,5	8449700.940x.xxxxx

Note to Pressure Equipment Directive (PED):

The valves of this series up to and including DN 25 (G1) are according to Art. 4 § 3 of the Pressure Equipment Directive (PED) 2014/68/EU. This means interpretation and production are in accordance to engineers practice wellknown in the member countries. The CE-sign at the valve does not refer to the PED. Thus the declaration of conformity is not longer applicable for this directive.

For valves > DN 25 (G1) Art. 4 § (1) Letter d) applies:

The basic requirements of the Enclosure I of the PED must be fulfilled. The CE-sign at the valve includes the PED. A certificate of conformity of this directive will be available on request.

Note to Electromagnetic Compatibility Guideline (EEC):

The valves shall be provided with an electrical circuit which ensures the limits of the harmonised standards EN 61000-6-3 and EN 61000-6-1 are observed, and hence the requirements of the Electromagnetic Compatibility Guideline (2014/30/EU) satisfied.

Note to EAC marking:

The EAC-marked products comply with the applicable requirements stated in the technical regulations of the Eurasian Economic Union.