

82960/82970

2/2-way diaphragm valves

- Port size: DN 20 ... 80, G3/4 ... 3 (ISO G/NPT)
- High flow rate
- All internal components captive
- Clear, compact design
- Solenoid interchangeable without tools (Twist-on®)
- Integrated silencer
- One-piece diaphragm
- Also available for solenoid version low temperature to –40°C (–40°F)
- International approvals



Technical features

Medium:
Air

Switching function:
Normally closed

Flow direction:
Determined

Mounting position:
Optional, preferably solenoid vertical on top

Port size:
G3/4, G1, G1 1/2, G2, G2 1/2, G3, 3/4 NPT, 1 NPT, 1 1/2 NPT, 2 NPT

Operating pressure:
0,4 ... 8 bar (5,8 ... 116 psi)

Dusty gas temperature:
–40 ... +85°C (–40 ... +185°F)

Ambient temperature:
–20 ... +85°C (–4 ... +185°F)

Cleaning gas temperature:
–40 ... +85°C (–40 ... +185°F)

Material:
Body: Aluminium
Seat seal: TPE
Internal parts: TPU

Technical data – standard models

Symbol	Port size	Orifice (mm)	Valve length (mm)	Flow kv value *1) (m ³ /h)	Operating pressure (bar) (psi)		Weight (kg)	Model Solenoid in V d.c./a.c.
	G3/4	20	95	18	0,4 ... 8	5,8 ... 116	0,5	8296300.8171.xxxxx
	3/4 NPT	20	95	18	0,4 ... 8	5,8 ... 116	0,5	8297300.8171.xxxxx
	G1	25	95	22	0,4 ... 8	5,8 ... 116	0,47	8296400.8171.xxxxx
	1 NPT	25	95	22	0,4 ... 8	5,8 ... 116	0,47	8297400.8171.xxxxx
	G1 1/2	40	135	59	0,4 ... 8	5,8 ... 116	1,18	8296600.8171.xxxxx
	1 1/2 NPT	40	135	59	0,4 ... 8	5,8 ... 116	1,18	8297600.8171.xxxxx
	G2	50	169	80	0,4 ... 8	5,8 ... 116	2,02	8296700.8171.xxxxx
	2 NPT	50	169	80	0,4 ... 8	5,8 ... 116	2,02	8297700.8171.xxxxx
	G2 1/2	65	169	93	0,4 ... 8	5,8 ... 116	2,3	8296800.8171.xxxxx
	G3	80	239,5	172	0,4 ... 8	5,8 ... 101	3,93	8296900.8171.xxxxx

xxxxx Please insert voltage and frequency codes

*1) Cv-value (US) ≈ kv value x 1,2

Option selector

829****.8171.*****

Thread form	Substitute
ISO G	6
NPT	7
Port size	Substitute
3/4	3
1	4
1 1/2	6
2	7
2 1/2 (only ISO G)	8
3 (only ISO G)	9
Valve options	Substitute
Flange version without valve body	54
Dusty gas temperature -40 ... +100°C (-40 ... +212°F), Seat seal TPE, Ambient temperature -20 ... +85°C (-4 ... +185°F), Cleaning gas temperature -40 ... +85°C (-40... +185°F)	62

Frequency	Substitute
See table frequency codes	xx
Voltage	Substitute
See table voltage codes	xxx
Valve options	Substitute
Dusty gas temperature -40 ... +140°C (-40 ... +284°F), Seat seal TPE, Ambient temperature -20 ... +85°C (-4 ... +185°F), Cleaning gas temperature -40 ... +85°C (-40 ... +185°F)	63
Low temperature version Dusty gas temperature -40 ... +85°C (-40 ... +185°F), Seat seal TPE, Ambient temperature -40 ... +85°C (-40 ... +185°F), Cleaning gas temperature -40 ... +85°C (-40 ... +185°F) Not in combination with with solenoid system 817x	71

Standard solenoid systems

Voltage and Frequency Solenoid 8171 *2)					
Code Voltage	Code Frequency	Voltage	Frequency	Power consumption	
				Inrush	Holding
024	00	24 V d.c.	-	12 W	12 W
024	50	24 V a.c.	50 Hz	23 VA	16 VA
110	50	110 V a.c.	50 Hz	23 VA	16 VA
120	60	120 V a.c.	60 Hz	23 VA	16 VA
230	50	230 V a.c.	50 Hz	23 VA	16 VA

2*) US coil only

Electrical details for all solenoid systems

Design	DIN VDE 0580
Voltage range	±10%
Duty cycle	100% ED
Protection class	EN 60529 IP65
Socket	Form A acc. to DIN EN 175301-803 (included)

According to DIN VDE 0580 at a solenoid temperature of +20°C. At operating state temperature the input power of a coil decreases by up to ca. 30% due to physical reasons.

Additional solenoid systems for hazardous areas

ATEX category	ATEX protection class	IP protection class	Solenoid	Standard voltages
II 2G	Ex db mb IIC T4/T5 Gb	IP66	468x	24 V d.c., 110 V a.c., 230 V a.c.
II 2G	Ex eb mb IIC T4/T5 Gb			
II 2D	Ex tb IIIC T130°C Db			
II 3G	Ex ec IIC T4 Gc	IP65	8176	24 V d.c., 110 V a.c., 230 V a.c.
II 3D	Ex tc IIIC T130°C DC			
II 2G	Ex eb mb IIC T4 Gb	IP66	6176	24 V d.c., 110 V a.c., 230 V a.c.
II 2D	Ex mb tb IIIB T135°C Db			

Attention!

The conditions imposed on the Ex approvals lead to reduction of the permissible standard temperature ranges in the cases of explosion protected solenoids.

Additional solenoid systems

Option	Solenoid	Standard voltages
Solenoid version for low temperature -40°C	9151	24 V d.c., 110 V a.c., 230 V a.c.
Pulse Solenoid	8821	24 V d.c., 110 V a.c., 230 V a.c.
Solenoid version for low temperature -40°C	8001	24 V d.c., 110 V a.c., 230 V a.c.

Dimensions

G3/4 ... 1
3/4 ... 1 NPT

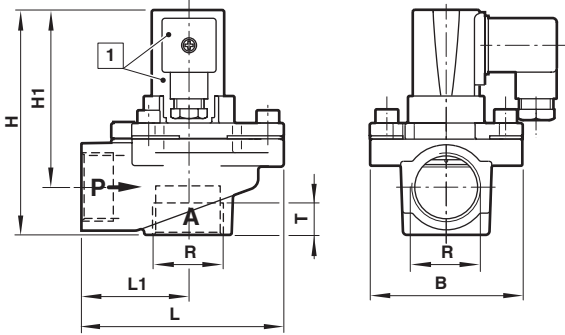

G1 1/2 ... 3
1 1/2 ... 2 NPT

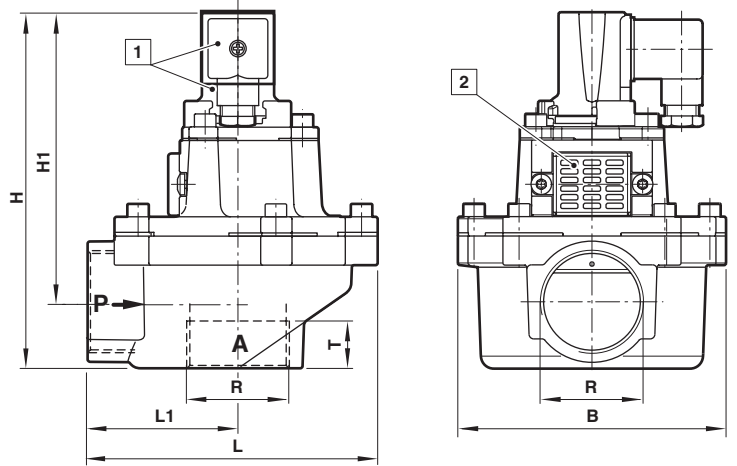

Dimensions in mm
Projection/first angle

- 1 Solenoid rotatable 360°
Socket turnable 4 x 90°
(Socket included)
- 2 Silencer

Port size R	B	H	H1	L	L1	T	Model
G3/4	80	105,5	83	95	50	16	8296300.8171.xxxxx
3/4 NPT	80	105,5	83	95	50	14	8297300.8171.xxxxx
G1	80	105,5	83	95	50	18	8296400.8171.xxxxx
1 NPT	80	105,5	83	95	50	17	8297400.8171.xxxxx
G1 1/2	124,5	166	136	135	70	22	8296600.8171.xxxxx
1 1/2 NPT	124,5	166	136	135	70	18	8297600.8171.xxxxx
G2	140	190,5	149	170	96,5	25	8296700.8171.xxxxx
2 NPT	140	190,5	149	170	96,5	18	8297700.8171.xxxxx
G2 1/2	140	205,5	160	170	96,5	25	8296800.8171.xxxxx
G3	196	221	169	239,5	143	33	8296900.8171.xxxxx

Note to Pressure Equipment Directive (PED):

The valves of this series are according to Art. 4 § 3 of the Pressure Equipment Directive (PED) 2014/68/EU. This means interpretation and production are in accordance to engineers practice wellknown in the member countries. The CE-sign at the valve does not refer to the PED. Thus the declaration of conformity is not longer applicable for this directive.

Note to Electromagnetic Compatibility Guideline (EEC):

The valves shall be provided with an electrical circuit which ensures the limits of the harmonised standards EN 61000-6-3 and EN 61000-6-1 are observed, and hence the requirements of the Electromagnetic Compatibility Guideline (2014/30/EU) satisfield.

Note to EAC marking:

The EAC-marked products comply with the applicable requirements stated in the technical regulations of the Eurasian Economic Union.