

## 83920 2/2-way valves

- Port size: For tank mounting with blow-tube
- Orifice: DN 25 ... 65
- High flow rate
- All internal components captive
- Clear, compact design
- Solenoid interchangeable without tools (Twist-on®)
- Integrated silencer
- International approvals

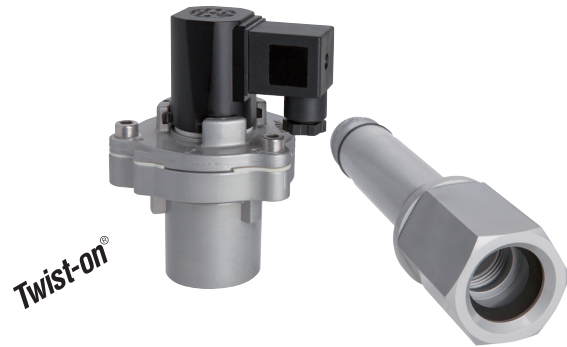

### Technical features

**Medium:**  
Neutral gases

**Type:**  
Diaphragm valve requiring differential pressure

**Switching function:**  
Normally closed

**Operation:**  
Pilot operated solenoid valve for cleaning dust filters

**Flow direction:**  
Determined

**Mounting position:**  
Optional, preferably solenoid vertical on top

**Port size:**  
DN 25, DN 40, DN 50, DN 65

**Operating pressure:**  
0,4 ... 8 bar (5,8 ... 116 psi)

**Differential pressure:**  
0,4 bar (5,8 psi) required

**Dusty gas temperature:**  
–40 ... +85°C (–40 ... +185°F)

**Cleaning gas temperature:**  
–40 ... +85°C (–40 ... +185°F)

**Ambient temperature:**  
–20 ... +85°C (–4 ... +185°F)

**Material:**  
Body: Aluminium  
Seat seal: TPE  
Seals: TPU  
Blow-tube: Aluminium  
Adapter: Aluminium

### Technical data – standard models

Symbol	Orifice (mm)	Flow kv value *1) (m³/h)	Operating pressure		Weight (kg)	Model Solenoid in V d.c. / a.c.
			(bar)	(psi)		
	25	28	0,4 ... 8	5,8 ... 116	0,47	8392400.8171.xxxxx
	40	74	0,4 ... 8	5,8 ... 116	1,1	8392600.8171.xxxxx
	50	104	0,4 ... 8	5,8 ... 116	1,6	8392700.8171.xxxxx
	65	121	0,4 ... 8	5,8 ... 116	2	8392800.8171.xxxxx

xxxxx Please insert voltage and frequency codes

\*1) Cv-value (US) ≈ kv value x 1,2

Outside dim. of tank/profile (mm)	Model		plus	Connector kit			
	DN 25	DN 40		Hose connector	Female thread	Male thread	Push-in sleeve
70	8392400.8171.00000	-	+	1263648	1263641	1263634	1263628
100				1263649	1263642	1263635	1263629
120				1263652	1263643	1263636	1263630
140				1263653	1263644	1263637	1263609
160				1263655	1263645	1263638	1263631
180				1263656	1263646	1263639	1263632
200	1263657	1263647	1263640	1263633			
70	-	8392600.8171.00000	+	1263682	1263674	1263666	1263658
100				1263683	1263675	1263667	1263659
120				1263684	1263676	1263668	1263660
140				1263685	1263677	1263669	1263661
160				1263686	1263678	1263670	1263662
180				1263687	1263679	1263671	1263663
200				1263688	1263680	1263672	1263664

Kit not required for use without connection pipe. Please then just give Order-No. for DN 25 or 40 connection.  
 DN 50 and DN 65 – Tube and connection on request

8392★00.8171.★★★★★

Port size	Substitute
25	4
40	6
50	7
60	8

Frequency	Substitute
See table frequency codes	xx
Voltage	Substitute
See table voltage codes	xxx

### Standard solenoid systems

Voltage and Frequency Solenoid 8171					
Code Voltage	Code Frequency	Voltage	Frequency	Power consumption	
				Inrush	Holding
024	00	24 V d.c.	-	12 W	12 W
024	50	24 V a.c.	50 Hz	23 VA	16 VA
110	50	110 V a.c.	50 Hz	23 VA	16 VA
120	60	120 V a.c.	60 Hz	23 VA	16 VA
230	50	230 V a.c.	50 Hz	23 VA	16 VA

### Electrical details for all solenoid systems

Design	DIN VDE 0580
Voltage range	±10%
Duty cycle	100% ED
Protection class	EN 60529 IP65
Socket	Form A acc. to DIN EN 175301-803 (included)

According to DIN VDE 0580 at a solenoid temperature of +20°C.  
 At operating state temperature the input power of a coil decreases by up to ca. 30% due to physical reasons.

### Additional solenoid systems for hazardous areas

ATEX category	ATEX protection class	IP protection class	Solenoid	Standard voltages
II 2G II 2D	Ex eb mb IIC T6...T4 Gb Ex tb IIIC T130°C Db	IP66	42xx	24 V d.c., 110 V a.c., 230 V a.c.
II 2G II 2D	Ex d mb IIC T4/T5 Gb Ex tb IIIC T130°C/T95°C Db	IP66	468x	24 V d.c., 110 V a.c., 230 V a.c.
II 3G II 3D	Ex ec IIC T4 Gc Ex tc IIIC T130°C DC	IP65	8176	24 V d.c., 110 V a.c., 230 V a.c.
II 2G II 2D	Ex eb mb IIC T4 Gb Ex mb tb IIIB T135°C Db	IP66	6176	24 V d.c., 110 V a.c., 230 V a.c.

#### Attention!

The conditions imposed on the Ex approvals lead to reduction of the permissible standard temperature ranges in the cases of explosion protected solenoids.

Dimensions  
DN 25

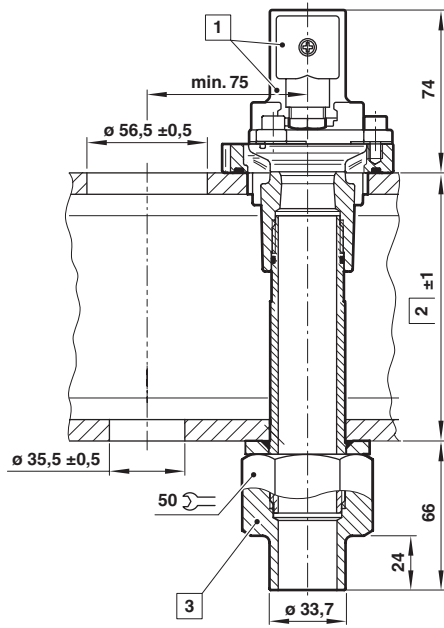

DN 40 ... 65

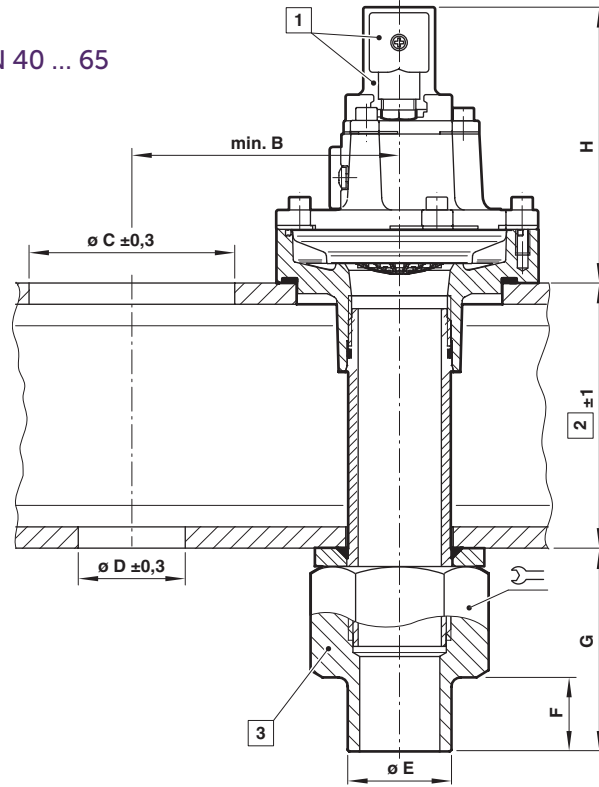

Dimensions in mm  
Projection/first angle

1 Solenoid rotatable 3 x 120°  
Socket turnable 4 x 90°  
(Socket included)

2 Profile

3 Hose connector

Orifice (mm)	B	ø C	ø D	ø E	F	G	H		Model
25	see drawing								8392400.8171.xxxxx
40	125	96	50	48,6	30	81	129	65	8392600.8171.xxxxx
50	200	116	61	60,3	60	118	135	80	8392700.8171.xxxxx
65	200	116	77	76	70	145	145	95	8392800.8171.xxxxx

Maximum torque 50 Nm for DN 25 adapter  
Maximum torque 100 Nm for DN 40, DN 50, DN 65 adapter

Other adapters

Female thread

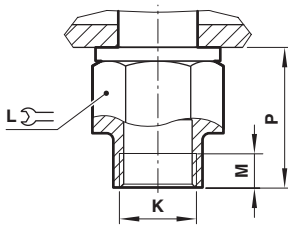

Male thread

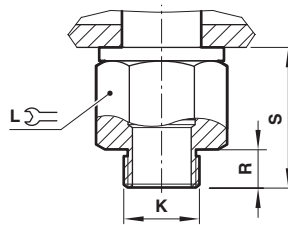

Hose connection

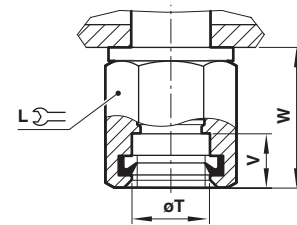

	Orifice (mm)	K	L	M	P	R	S	ø T	V	W
Female thread	25	G1	6kt, 65	15	62	-	-	-	-	-
Female thread	40	G1 1/2	6kt, 65	23	81	-	-	-	-	-
Male thread	25	G1	6kt, 65	-	-	17	62	-	-	-
Male thread	40	G1 1/2	6kt, 65	-	-	25	81	-	-	-
Hose connection	25	-	6kt, 65	-	-	-	-	33,7	24	66
Hose connection	40	-	6kt, 65	-	-	-	-	48,3	40	91

**Note to Pressure Equipment Directive (PED):**

The valves of this series are according to Art. 4 § 3 of the Pressure Equipment Directive (PED) 2014/68/EU. This means interpretation and production are in accordance to engineers practice wellknown in the member countries. The CE-sign at the valve does not refer to the PED. Thus the declaration of conformity is not longer applicable for this directive.

**Note to Electromagnetic Compatibility Guideline (EEC):**

The valves shall be provided with an electrical circuit which ensures the limits of the harmonised standards EN 61000-6-3 and EN 61000-6-1 are observed, and hence the requirements of the Electromagnetic Compatibility Guideline (2014/30/EU) satisfied.

**Note to EAC marking:**

The EAC-marked products comply with the applicable requirements stated in the technical regulations of the Eurasian Economic Union.